



AFS—BC Chapter MAY NEWSLETTER

We're on the web!
<http://www.afsbc.ca>

Board of Directors:

- > Jim Coulman: Chair
Levelton
met@levelton.com
- > Crystal Lambert: Vice Chair
Purity Casting Alloys Ltd.
sales@purityalloys.com
- > Casey Sheriland: Secretary/Treasurer
Highland Foundry
csheriland@highlandfoundry.com
- > Drew Johnston: Sports Director
Rypac Aluminum
d-sjohnston@telus.net
- > David Lalonde: Sports Director
Inproheat
dlalonde@inproheat.com
- > Derek Morrison: Apprenticeship/
Membership
Robar Industries
derek.morrison@robar.ca
- > Eric Hasselmann: Director at Large
Century Pacific Foundry
eric@century-pacific.com
- > Kia Damghani: Entertainment Director
Thompson Foundry
kia@telus.net
- > Ray Tyers: Past Chair
OCL Industries
ray@oclim.com

Annual General Meeting and Ladies Appreciation Evening

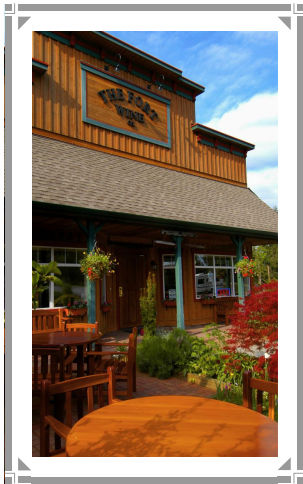

We are pleased to announce the date and time of the much anticipated May Annual General Meeting.

Join us at the event and taste the 100% grape free made from local British Columbia fruit wine. Delicious wines will be served that are simply enjoyed by the glass.

We will also be hosting a wine and chocolate seminar along with a BBQ chicken feast!

Please join us for an fun evening of wine tasting in the Valley!



Date: May 14, 2011
Time: 6:00pm cocktails;
7:00pm dinner

Location: Fort Langley Winery
Cost: \$80pp

April Seminar Recap—Green Sand, by attendee Ray Tyers

The instructors Steven and Vic covered a very broad topic in a clear and logical manner.

They started with the basics, what is green sand? Starting with the basics, sand clay and water they then covered the various categories of additives and how they effect the various properties of green sand moulds. Vic explained how the various clays and additives effect the physical properties of the sand in relation to the metal

being poured. Vic further explained why you would want a particular property over another and how a few of the additives can give conflicting results.

The second part of the talk was devoted to sand testing and the defects than can be caused by your sand system. Steve explained what each of the basic sand tests are and how to interpret the results.

The final part was to take all the

discussed knowledge and explain how the various components of green sand can cause defects and how to minimize said defects.

The Delta town and country provided us with a great spread of sandwiches and snacks, topped off by an assortment of treats that make a day out of the foundry worth any foundry person's time

Inside this issue:	
May AGM Notice	1
April Seminar Recap	1
Spring Golf Notice	2
Lethbridge Casting Wins!	2
Rules for a Good Casting	3
Just-In-Time Education	3
Calendar Of Events	4



Spring Golf Tournament

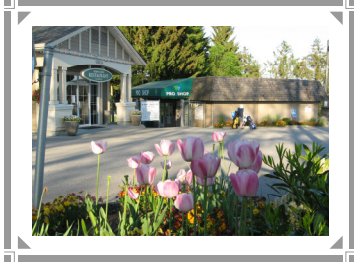

Fort Langley Golf Course is a hidden gem in a country setting. With various water hazards, famous St. Andrews-style pot bunkers, smooth greens and a few extra-long par 4 holes, it is an enjoyable challenge that will require every club in your bag!

For only \$95 enjoy 18 holes of golf, Callaway Scoring, Awards, Trophies and a Steak BBQ Dinner. Guests coming for dinner only, \$40.

Power Carts must be booked in advance at an additional cost of \$40 each (\$20 per person). Call 604.888.5911 to book your cart today, supply limited.

Submit your preferred four-somes by April 29, 2011.

Date: May 11, 2011
Time: 11:00am
Cost: \$95 for golf & dinner;
\$40 for dinner only

CONTACT: Drew Johnston, Rypac Aluminum Recycling Ltd.
Ph: 604.580.7471 Email: d-johnston@telus.net

or David Lalonde, Inproheat Industries Ltd.
Ph: 604.254.0461 Email: dlalonde@inproheat.com

Company sponsorships are welcomed for our prize table and trophies!

Alkali metals such as sodium, potassium, rubidium, caesium and francium are extremely reactive elements.

Lethbridge Iron Works Wins Casting of the Year Award

Schaumburg, Ill... The metal-casting industry recognized nine cast components as top designs for the 2011 American Foundry Society/ *Metal Casting Design & Purchasing* Casting Competition. The components are used in a variety of industries, including automotive, construction, agriculture and military.

Lethbridge Iron Works Co. Ltd., Lethbridge, Canada, and Eck Industries, Manitowoc, Wis., earned top honors in the annual competition. Lethbridge's Front Cab Support

Bracket is designed to support the cab of a Daimler Western Star model truck. The green sand casting has been redesigned several times over the years to meet changing packaging requirements. For the latest redesign, Daimler worked closely with Lethbridge to consolidate an assembly of three castings, seven welded assemblies and 16 low-level parts into two castings, zero welded assemblies and four low-level parts.

Lethbridge's ductile iron component weighs 35.3 lbs. and measures 18 x 16 x 9 in. Converting the front cab support bracket

from a weldment delivered the customer a 22% weight savings and 35% cost savings per vehicle.

This year's Casting Competition was sponsored by Magma Foundry Technologies, Schaumburg, Ill. Magma will provide Lethbridge Iron Works and Eck Industries with a one-year license of Magmasoft software, including training and implementation assistance.

For more information on the 2011 AFS/ *Metal Casting Design & Purchasing* Casting Competition, contact Dave Krugman, AFS, at dkrugman@afsinc.org or





10 Rules For A Good Casting

Rule 10. Provide Location Points

All castings will be provided with agreed location points for dimensional reference and for pickup for machining. The combination of clamping points to be used during machining is also usually helpful and easily incorporated.

These drawings show ways in which the six-point location method can be used on a casting.

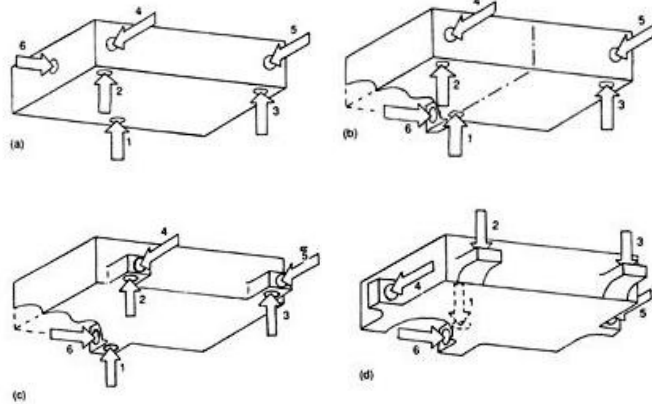

Just-In-Time Education—AFS Headquarters—Webinars

AFS and CMI produce many educational opportunities to keep metalcasters abreast of the latest technical, environmental, health and safety and industry marketing trends. There are many internet courses and webinars that have been produced just in time for you to make your facility more productive. For

more information on internet courses contact Jennifer Head, CMI director of education, at jhead@afsinc.org. To inquire about webinars, contact Dave Krugman, AFS PR and marketing coordinator, at dkrugman@afsinc.org.

Current Upcoming Webinars:

Ferrous Alloy Selection for Metal Castings: How do properties allow the customer to choose an appropriate alloy?

Foundry Sand Beneficial Use Toolkit: the tools and resources that you can use to begin the process.

By just putting Akali metals in water can result in an explosion!

They are carefully stored in oil to prevent this happening

Just-In-Time Education—AFS Headquarters—Internet Courses

CMI offers several options for on-demand, self-paced internet courses. Short-format courses range from 30 minutes to 2 hours, and full-length courses mirror the content taught in their live 2 and 3 days lecture courses. Most are taken through CMI's e-learning website located at <http://castmetalselearning.com>, while

a few are hosted by Banu Learning Systems. Individuals view narrated, PowerPoint-based presentations and complete assessments to test comprehension. PDF copies of the presentations are available for download, and certificates of completion become available for printing after passing the assessment.

Upcoming Internet Courses:

Introduction to Metalcasting: This introductory course presents a general overview of the metalcasting process. Topics covered include patternmaking, molding and coremaking processes, alloys poured, melting methods, gating and risering, cleaning and finishing, defects, and inspection techniques.



Forgemasters made engineering history in 2005 with this 340 tonnes casting. It was the largest steel casting made in Europe

Chapter Sponsors

Corporate Members:

Inproheat Industries Ltd., Lethbridge Ironworks Ltd., Norwood Foundry Ltd., DCL Industrial Materials Ltd., Westmat Supplies Ltd.

Platinum Sponsors:



Gold Sponsors:

Midan Industries, Millbanks Materials, Rypac Aluminum Recycling, Robar Industries, Thompson Foundry

Letters to the Editor:
 Crystal Lambert
 AFS - BC Chapter
 c/o Purity Casting Alloys Ltd.
 #15 - 18503, 97th Ave
 Surrey, BC V4N 3N9
 Phone: 604-888-0181
 Fax: 604-888-8318
 E-mail: sales@purityalloys.com

Calendar Of Events

Date/Time	Event	Location
Thursday March 31–April 2	Oregon Chapter NW Regional	Portland, Oregon
Thursday March 17 Time: 3:30–6:30pm	March Meeting: Advancements in Treating and Monitoring Molten Aluminum	Delta Town and County Inn, Delta, BC
Wednesday April 13 Time: 9:30am–2:30pm	April Meeting: Green Sand Seminar presented by Vic Lafay	Delta Town and Country Inn, Delta, BC
Thursday May 12 Time: 11:00am	Spring Golf Tournament	Fort Langley Golf Course
Saturday May 14 Time: 6:00pm	Annual General Meeting and Ladies Appreciation Night	Fort Langley Wine Co.

We're on the web!
<http://www.afsbc.ca>